

OWNERS MANUAL

Model No.
45-0292

CAUTION:
Read Rules for
Safe Operation
and Instructions
Carefully

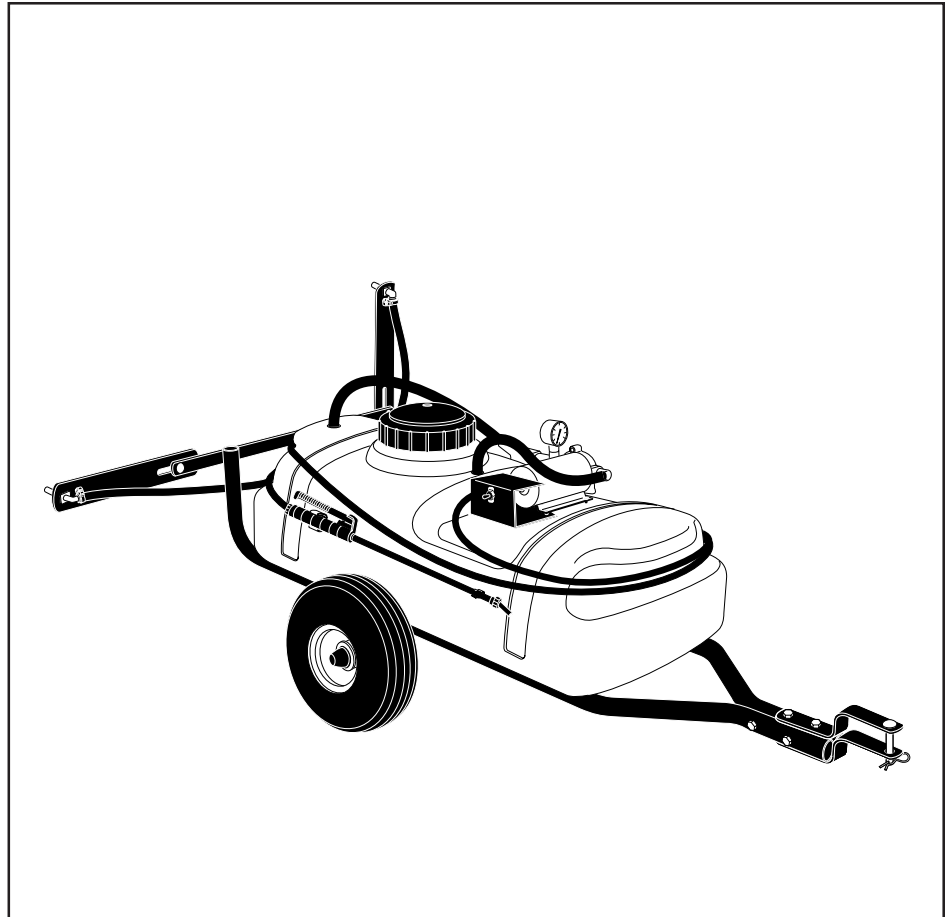

15 GALLON "PRO" TOW SPRAYER

- Assembly
- Operation
- Maintenance
- Repair Parts

RULES FOR SAFE OPERATION

Any power equipment can cause injury if operated improperly or if the user does not understand how to operate the equipment. Exercise caution at all times when operating equipment.

1. Read this owners manual carefully before attempting to assemble or operate this sprayer.
2. Read your vehicle owners manual for operating and safety rules before using this equipment.
3. Never allow children to operate this sprayer, and do not allow adults to operate without proper instructions.
4. Do not allow anyone to ride on or sit on this sprayer. Do not allow passengers on the towing vehicle.
5. Keep the area of operation clear of all persons, particularly small children. Also keep area clear of pets.
6. Read the chemical label carefully for instructions and caution notes on handling and mixing of chemicals.
7. Wear eye and hand protection and wear protective clothing when handling and applying lawn chemicals.
8. Do not spray on windy days.
9. Attachment of this sprayer may affect your tractor's braking and stability. Be aware of your tractor's capabilities. Refer to the safety rules in the vehicle owner's manual concerning safe operation on slopes. Be aware of changing conditions on slopes. **STAY OFF OF STEEP SLOPES.**
10. Operate at reduced speed on rough terrain, along ditches and on hillsides to prevent loss of control.
11. Follow maintenance and lubrication instructions as outlined in this manual.



LOOK FOR THIS SYMBOL TO POINT OUT IMPORTANT SAFETY PRECAUTIONS. IT MEANS --ATTENTION! BECOME ALERT! YOUR SAFETY IS INVOLVED.

Your sprayer carton contains parts as shown in figure 1. The hardware package contains parts as shown in figure 2. Identify all parts and layout as shown in figures 1 and 2.

CARTON CONTENTS

LOOSE PARTS IN CARTON

- | | |
|--|------------------------|
| 1. Lid | 6. Hitch Tube, R.H. |
| 2. Tank | 7. Hitch Tube, L.H. |
| 3. Return/Bypass Hose (may be assembled to tank) | 8. Boom Mount Bracket |
| 4. Boom Assembly | 9. Hitch Brackets (2) |
| 5. Axle | 10. Spray Gun Assembly |
| | 11. Wheels (2) |

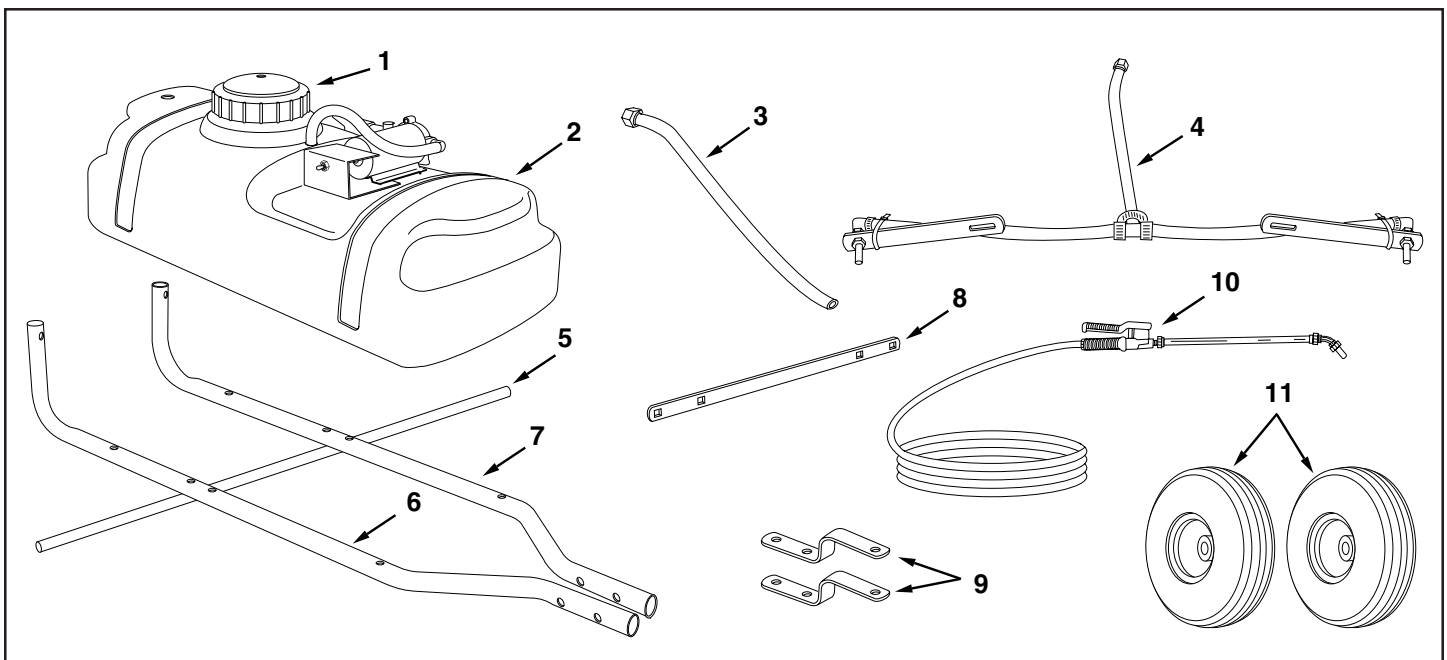

SHOWN FULL SIZE

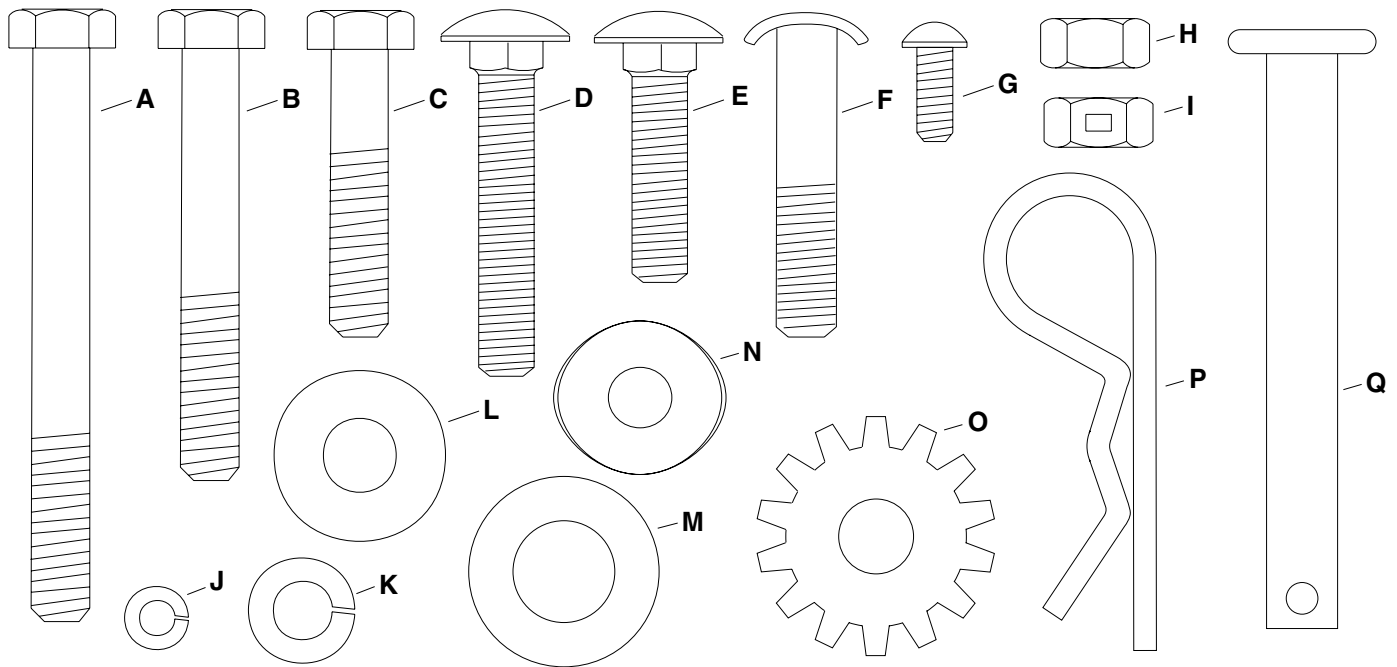

NOT SHOWN FULL SIZE

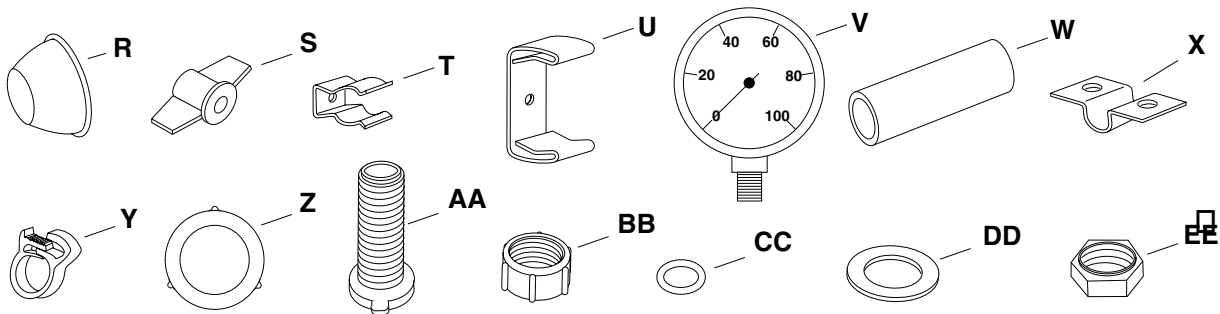

HARDWARE PACKAGE - FULL SIZE

KEY	QTY.	DESCRIPTION	KEY	QTY.	DESCRIPTION
A	2	Bolt, Hex 5/16" x 3"	P	1	Hair Cotter Pin
B	2	Bolt, Hex 5/16" x 2-1/4"	Q	1	Hitch Pin
C	4	Bolt, Hex 5/16" x 1-1/2"	R	2	Hub Cap
D	2	Bolt, Carriage 5/16" x 1-3/4"	S	2	Knob
E	2	Bolt, Carriage 5/16" x 1-1/4"	T	1	Spray Gun Clip, Small
F	4	Bolt, Curved Head, 5/16" x 1-5/8"	U	1	Spray Gun Clip, Large
G	2	Screw, #10 x 1/2"	V	1	Pressure Gauge
H	6	Hex Nut, 5/16"	W	2	Spacer
I	4	Hex Lock Nut, 5/16"	X	2	Axle Clamp
J	2	Lock Washer, #10	Y	1	Hose Clamp, 1/4"
K	16	Lock Washer 5/16"	Z	3	Gasket, 3/4" Garden Hose
L	2	Flat Washer, 5/16"	AA	1	Drain Body
M	4	Flat Washer, 1/2"	BB	1	Nylon Cap
N	4	Washer, Bowed	CC	1	O-Ring
O	2	Washer, 5/16" Tooth Lock	DD	1	Nylon Washer, 11/16"
			EE	1	Nylon Nut

ASSEMBLY INSTRUCTIONS

TOOLS REQUIRED FOR ASSEMBLY

- (2) 1/2" Wrenches
- (1) Screwdriver
- (1) Pliers
- (1) Hammer

1. Remove all items from carton and lay out as shown on pages 2 and 3.
2. Assemble the axle clamps to the hitch tubes using four curved head bolts, 5/16" lock washers and 5/16" hex nuts. **Do not tighten yet.** See figure 1.

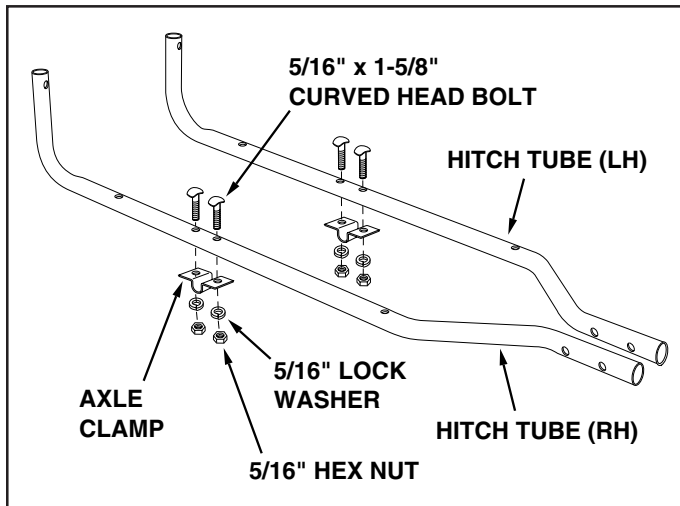

FIGURE 1

3. Assemble the hitch tubes to the tank using four 5/16" x 1-1/2" hex bolts, 5/16" lock washers and bowed washers. Place the bowed washers between the tank and the hitch tubes. **Do not tighten yet.** See figure 2.

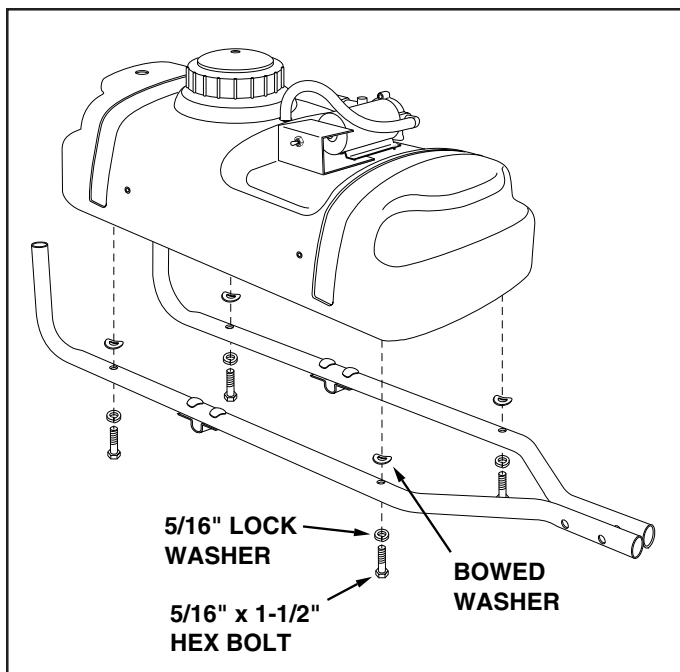

FIGURE 2

4. Fasten the hitch tubes together at the front using two 5/16" x 3" hex bolts, four 5/16" lock washers and two 5/16" hex lock nuts. **Do not tighten yet.** See figure 3.

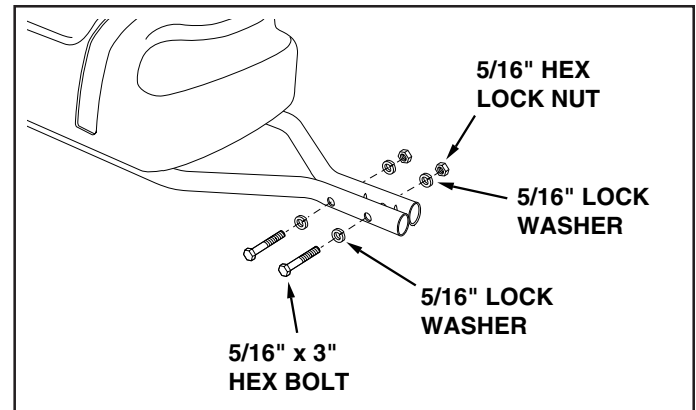

FIGURE 3

5. Assemble the two hitch brackets to the front of the hitch tubes using two 5/16" x 2-1/4" hex bolts, 5/16" lock washers and 5/16" hex lock nuts. **Do not tighten yet.** See figure 4.
6. Assemble the hitch pin to the hitch brackets and secure it with the 1/8" hair cotter pin. See figure 4.

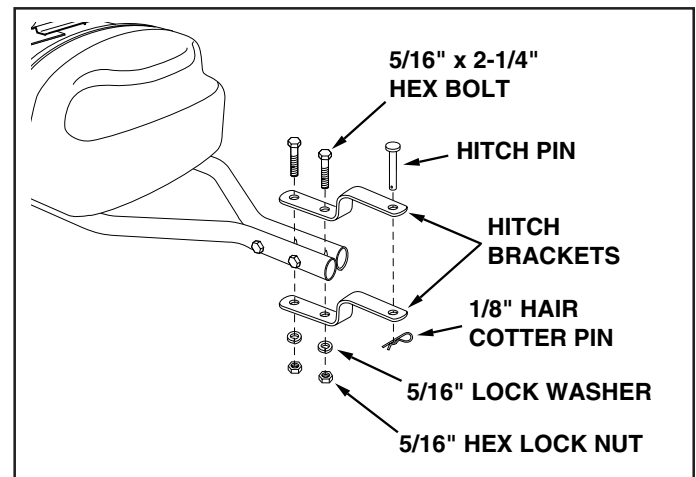

FIGURE 4

7. Assemble the boom mount bracket to the rear of the hitch tubes using two 5/16" x 1-3/4" carriage bolts, 5/16" lock washers and 5/16" hex nuts. **Do not tighten yet.** See figure 5.

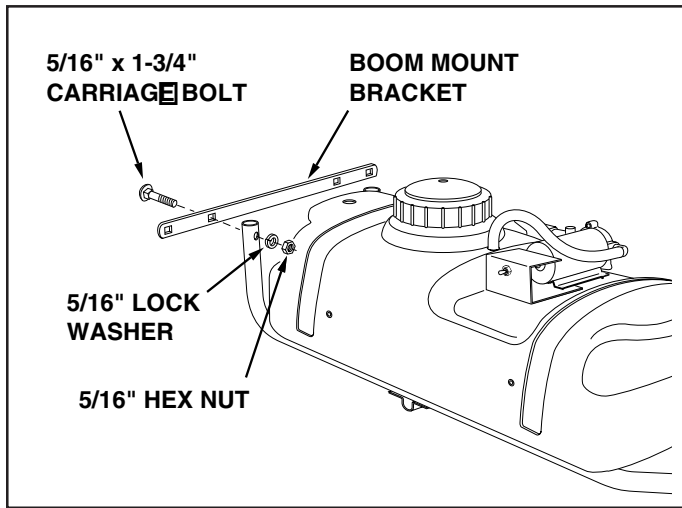

FIGURE 5

8. Slide the axle through the two axle brackets. See figure 6.
9. Assemble a spacer, a 1/2" washer, a wheel (valve stem facing out) and another 1/2" washer onto the axle. Lightly tap a hub cap onto the end of the axle. Repeat on other end of axle. See figure 6.

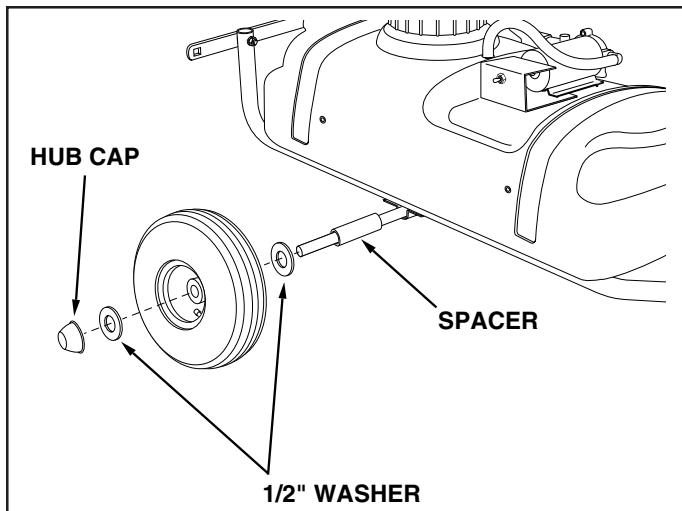

FIGURE 6

10. **Tighten** the four bolts which fasten the hitch tubes to the bottom of the tank. See figure 2.
Tighten the four hex nuts which fasten the axle brackets to the hitch tubes. See figure 1.
Tighten the two bolts which fasten the front of the hitch tubes together. See figure 3.
Tighten the two bolts which fasten the hitch brackets to the hitch tubes. See figure 4.
Tighten the two bolts which fasten the boom mount bracket to the rear of the hitch tubes. See figure 5.

11. Install the drain in the rear of the tank as shown in figure 7. Place a 3/4" garden hose gasket onto the drain body and insert the drain body out through the hole in rear of the tank. Outside the tank, assemble the nylon washer and then the nylon nut onto the drain body. Tighten the nut securely enough to prevent leaking, being careful not to damage the plastic parts. Place the O-ring inside the nylon cap and screw the cap onto the end of the drain body.

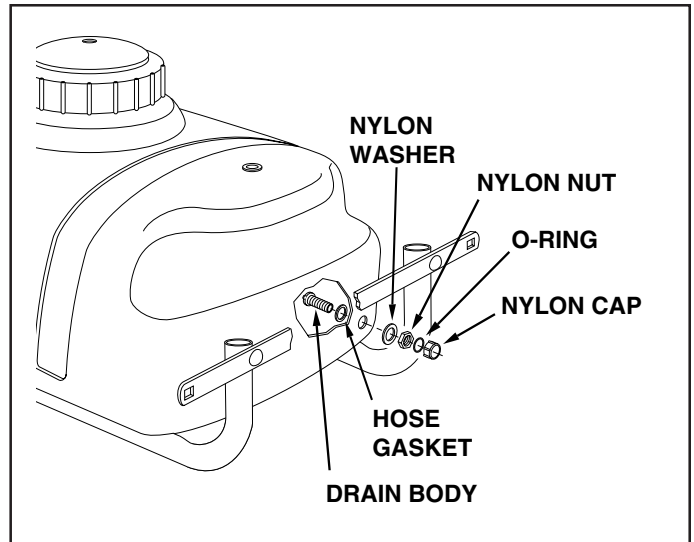

FIGURE 7

REAR VIEW

12. Assemble the boom bars to the boom mount bracket using two 5/16" x 1-1/4" carriage bolts, tooth lock washers (between the bar and bracket), 5/16" flat washers and knobs. The boom connecting hose should extend upward. See figure 8.
- NOTE:** Make sure the nozzles are adjusted so that the openings face straight down when the boom bar is in the horizontal operating position.

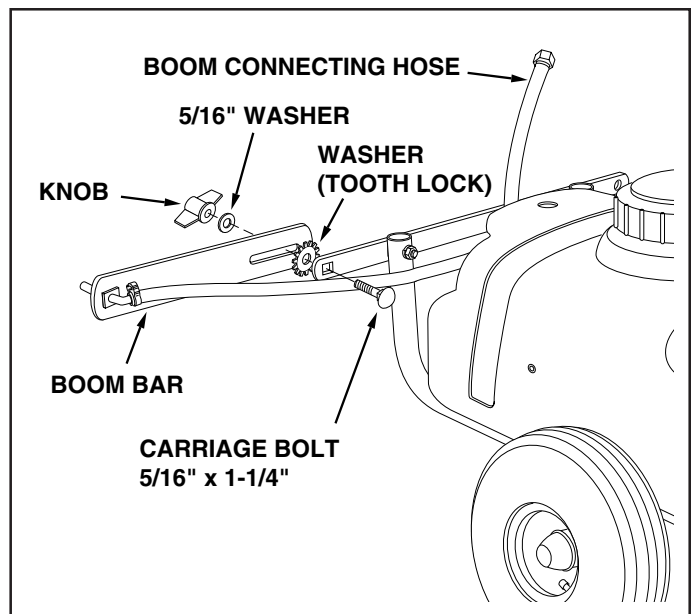

FIGURE 8

13. Assemble the large and small spray gun clips to the side of the tank using two #10 x 1/2" screws and #10 lock washers. See figure 9.

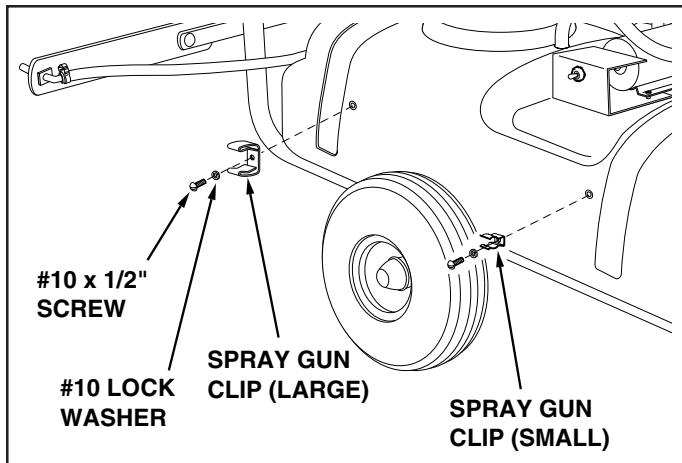

FIGURE 9

14. Insert a garden hose gasket into the swivel nut on the bypass/return hose. Screw the nut onto the upper outlet of the "Y" valve fitting. Place the other end of the hose down through the hole at the rear of the tank. See figure 10.

15. Insert a garden hose gasket into the swivel nut on the boom connecting hose. Screw the nut onto the lower outlet of the "Y" valve fitting. See figure 10.

16. Slide the 1/4" hose clamp onto the spray gun hose. Push the hose onto the hose adapter on the side of the "T" fitting as shown in figure 10. Tighten the clamp around the hose and the adapter. Wrap the hose around the tank and snap the spray gun into the clips on the side of the tank.

17. Carefully screw the pressure gauge into the top of the "T" fitting. See figure 10.

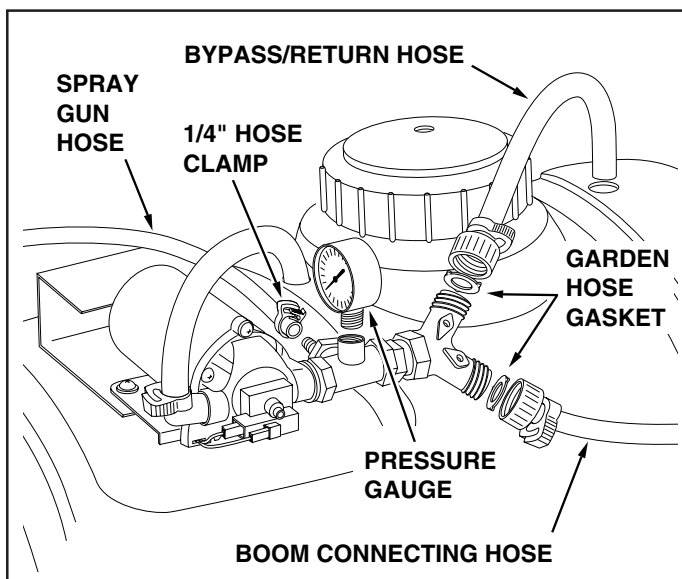

FIGURE 10

18. Attach the sprayer to the tractor hitch and connect the wiring to the tractor battery. The red wire must be connected to the positive post on the battery or to the "HOT" connection on a tractor switch or ammeter. The brown wire may be grounded or connected to the negative battery post. See figures 11 and 12.

IMPORTANT: This sprayer should be connected to 12 volt batteries only!

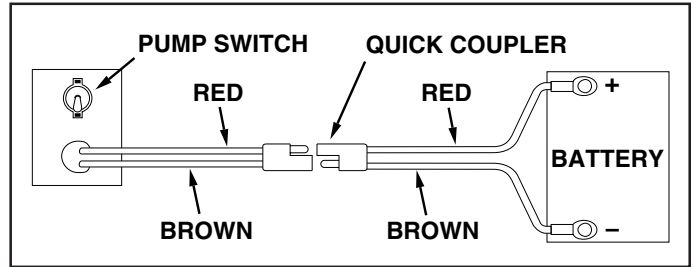

FIGURE 11

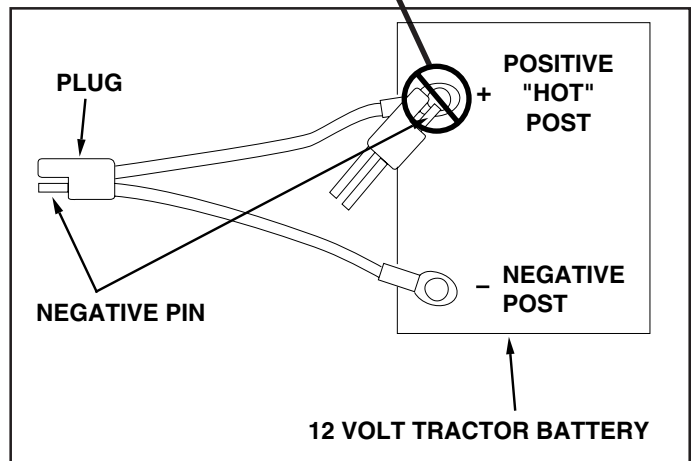

FIGURE 12

OPERATION

BEFORE STARTING

It is important to test the boom and spray gun with plain water before using chemicals. This will enable you to check the sprayer for leaks and to set the spray pattern and nozzle pressure. If a leak should occur, thread tape may be used to better seal the fitting.

PUMP PRESSURE SWITCH

The pump is equipped with a pressure switch. The pressure switch senses outlet pressure of the pump and will turn off the electrical power to the pump at a predetermined high pressure point (60 PSI). If the flow demand is very low, the pump may reach this high pressure point and the switch will cause "cycling" (the pump cycles on and off rapidly). This is not a problem unless the pump is subject to continuous cycling within one second intervals for long periods of time.

ADJUSTING OPERATING PRESSURE

The sprayer is equipped with a "Y" fitting containing a bypass valve and a boom valve. The bypass valve controls the flow to the return (bypass) hose. The amount of flow through the return hose determines the operating pressure when the boom or the spray gun is in use. Adjust the bypass valve while either the boom or the spray gun is in use to obtain the desired pressure, indicated by the pressure gauge. The tip chart on page 9 shows how different pressure settings affect boom application rates.

ON-OFF ADJUSTMENT OF BOOM NOZZLES

The boom valve on the "Y" fitting controls flow to the boom nozzles. It should be either completely open or completely closed. The boom operating pressure can be controlled using the bypass valve on the "Y" fitting.

ADJUSTING SPRAY GUN NOZZLE

Turn the nozzle on the spray gun to adjust the spray from a cone shaped fine mist to a straight stream. Control the spray gun operating pressure with the bypass valve on the "Y" fitting. Maximum spray gun pressure can be attained when the boom is shut off.

SETTING THE BOOM FOR SPRAYING

The correct positioning of the boom places the nozzles approximately 40" apart and 14" above the ground. This gives a spray width of approximately 80" with a slight center overlap. See figure 13.

- Slide the boom bars out to the ends of the slots.
- Swivel the boom bars until the nozzles are approximately 14" above the ground.
- Make sure the nozzles are adjusted so that the openings point straight down.

USING THE SPRAYER

- Determine the application rate (gallons per 1,000 sq. feet or gallons per acre) based on the chemical manufacturers recommendations. Use this rate to help select the pressure setting and tractor speed in the following instructions.
- Determine the approximate square footage of the area to be sprayed and estimate the number of gallons required. This can help avoid unneeded solution left in the tank.
- Determine the appropriate speed at which to travel, based on the chosen pressure setting and the recommended application rate. Use the tip chart on page 9.
- To determine the throttle setting for attaining the appropriate speed, mark off 100, 200 and 300 feet intervals. The speed chart at the bottom of page 9 indicates the number of seconds it takes to travel these distances. Set the throttle and, with a running start, travel the distances in the number of seconds indicated by the speed chart. Once you have determined the throttle and gear settings needed, mark the throttle location so that you can easily resume the same speed after stopping.
- Set the operating pressure. Spray with plain water to help determine the best setting. For best results stay in the 20 to 30 PSI range. (At 10 PSI the spray pattern begins to break up, at 40 PSI some drift develops.) Refer to the tip chart on page 9.
- Add the chemical solution to the tank, following the product instructions.
- Drive to the starting place for spraying. Set the boom in position for spraying. Set the throttle at the position determined in step 4. Reach back and flip the pump/motor switch "ON" to start spraying.
- Stay clear of flowers, shrubs and evergreen trees when spraying weed control solutions to prevent contact of the solution with these sensitive plants.



CAUTION: WEAR EYE PROTECTION, GLOVES AND PROTECTIVE CLOTHING WHEN HANDLING AND WORKING WITH LAWN CHEMICALS.

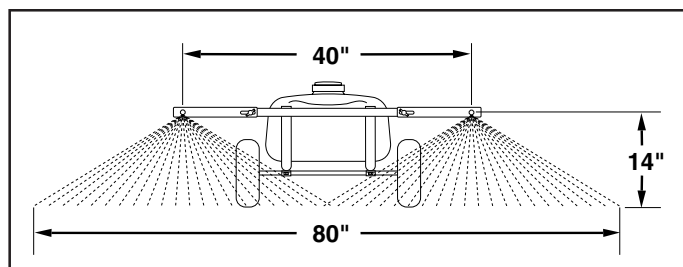

FIGURE 13

MAINTENANCE

1. Do not store sprayer with any solution left in tank.
2. Periodically clean the strainer in the end of the intake hose at the bottom of the tank. Remove the nylon swivel nut from the hose, pull out the screen and flush it with clear water.
3. Periodically clean the strainers in the boom nozzles. Remove the nozzle, pull out the screen and flush it with clear water.

AFTER EACH USE

4. After use, fill the sprayer part way with water, start the sprayer and allow clear water to be pumped through the plumbing system and out through the boom assembly and the handgun. Use the handgun to thoroughly wash all internal parts of the tank, the outside of the tank and the boom.
5. Refill the tank about half full with plain water and a chemical neutralizer and repeat the cleaning instructions above. Flush the entire sprayer with the neutralizing agent. Follow the chemical manufacturers instructions for disposal of all wash or rinsing water.

ATTENTION!

Do not allow chemicals to sit in pump for extended times of idleness. Some chemicals will damage the pump valve if allowed to soak untreated for a length of time. Always flush the pump with water after each use. Follow the procedures in the AFTER EACH USE instructions for flushing and disposal.

WINTER STORAGE

6. Drain all water out of the sprayer, paying special attention to the pump and handgun. These items are especially prone to damage from chemicals and freezing weather.
7. The sprayer should be winterized before storage by pumping a 50-50 solution of water and R. V. antifreeze through the entire plumbing. Proper care and maintenance will prolong the life of the sprayer.

U.S. GALLON TIP CHART

Tip No.	Spray Height Inches	Pressure PSI	Tip Capacity US Gallons Per Minute	GALLONS PER ACRE (BASED ON WATER)						
				1 MPH	2 MPH	3 MPH	4 MPH	5 MPH	7.5 MPH	10 MPH
		10	.30	44.2	22.1	14.8	11.1	8.9	5.9	4.4
#3	13"	20	.42	63	31.5	20.9	15.7	12.6	8.4	6.3
		30	.52	76.8	38.4	25.8	19.3	15.4	10.3	7.7
Tip No.	Spray Height Inches	Pressure PSI	Tip Capacity US Gallons Per Minute	GALLONS PER 1000 SQ. FT. (BASED ON WATER)						
				1 MPH	2 MPH	3 MPH	4 MPH	5 MPH	7.5 MPH	10 MPH
		10	.30	1.0	0.50	0.34	0.26	0.20	0.14	0.10
#3	13"	20	.42	1.4	0.72	0.48	0.35	0.29	0.19	0.14
		30	.52	1.8	0.88	0.59	0.44	0.35	0.24	0.18

IMPERIAL GALLON (LITER) TIP CHART

Tip No.	Spray Height Inches (mm)	Pressure PSI (Bar)	Tip Capacity Imperial Gallons per minute (liters per minute)	IMPERIAL GALLONS (Liters) PER ACRE (BASED ON WATER)						
				1 MPH 1.6 K/H	2 MPH 3.2 K/H	3 MPH 4.8 K/H	4 MPH 6.4 K/H	5 MPH 8 K/H	7.5 MPH 12 K/H	10 MPH 16 K/H
		10 (0.7)	.25 (1.135)	36.8 (167.3)	18.4 (83.6)	12.3 (56.0)	9.2 (42.0)	7.4 (33.7)	4.9 (22.3)	3.7 (16.7)
#3	13" (330 mm)	20 (1.4)	.35 (1.59)	52.5 (238.5)	26.2 (119.2)	17.4 (79.1)	13.1 (59.4)	10.5 (47.7)	7.0 (31.8)	5.2 (23.8)
		30 (2.1)	.433 (1.97)	64.0 (290.7)	32.0 (145.3)	21.5 (97.7)	16.1 (73.1)	12.8 (58.3)	8.6 (39.0)	6.4 (29.1)
Tip No.	Spray Height Inches (mm)	Pressure PSI (Bar)	Tip Capacity Imperial Gallons per minute (liters per minute)	IMPERIAL GALLONS (Liters) PER 1000 SQ. FT. (BASED ON WATER)						
				1 MPH 1.6 K/H	2 MPH 3.2 K/H	3 MPH 4.8 K/H	4 MPH 6.4 K/H	5 MPH 8 K/H	7.5 MPH 12 K/H	10 MPH 16 K/H
		10 (0.7)	.25 (1.135)	0.85 (3.85)	0.42 (1.92)	0.28 (1.29)	0.21 (0.97)	0.17 (0.77)	0.11 (0.51)	0.08 (0.38)
#3	13" (330 mm)	20 (1.4)	.35 (1.59)	1.21 (5.48)	0.60 (2.74)	0.40 (1.82)	0.30 (1.37)	0.24 (1.10)	0.16 (0.73)	0.12 (0.55)
		30 (2.1)	.433 (1.97)	1.47 (6.68)	0.74 (3.34)	0.49 (2.24)	0.37 (1.68)	0.29 (1.34)	0.20 (0.90)	0.15 (0.67)

GROUND SPEED CHART

M.P.H. (K/H)	Time Required in Seconds to Travel a Distance of:		
	100 ft (30.5 M)	200 ft (61 M)	300 ft (91.5 M)
1.0 (1.6)	68	136	205
2.0 (3.2)	34	68	102
3.0 (4.8)	23	45	68
4.0 (6.4)	17	34	51
5.0 (8.0)	14	27	41
6.0 (9.7)	11	23	34
7.0 (11.3)	9.7	19	29
8.0 (12.9)	8.5	17	26
9.0 (14.5)	7.6	15	23
10.0 (16.1)	6.8	14	20

REPAIR PARTS FOR 15 GALLON SPRAYER MODEL 45-0292

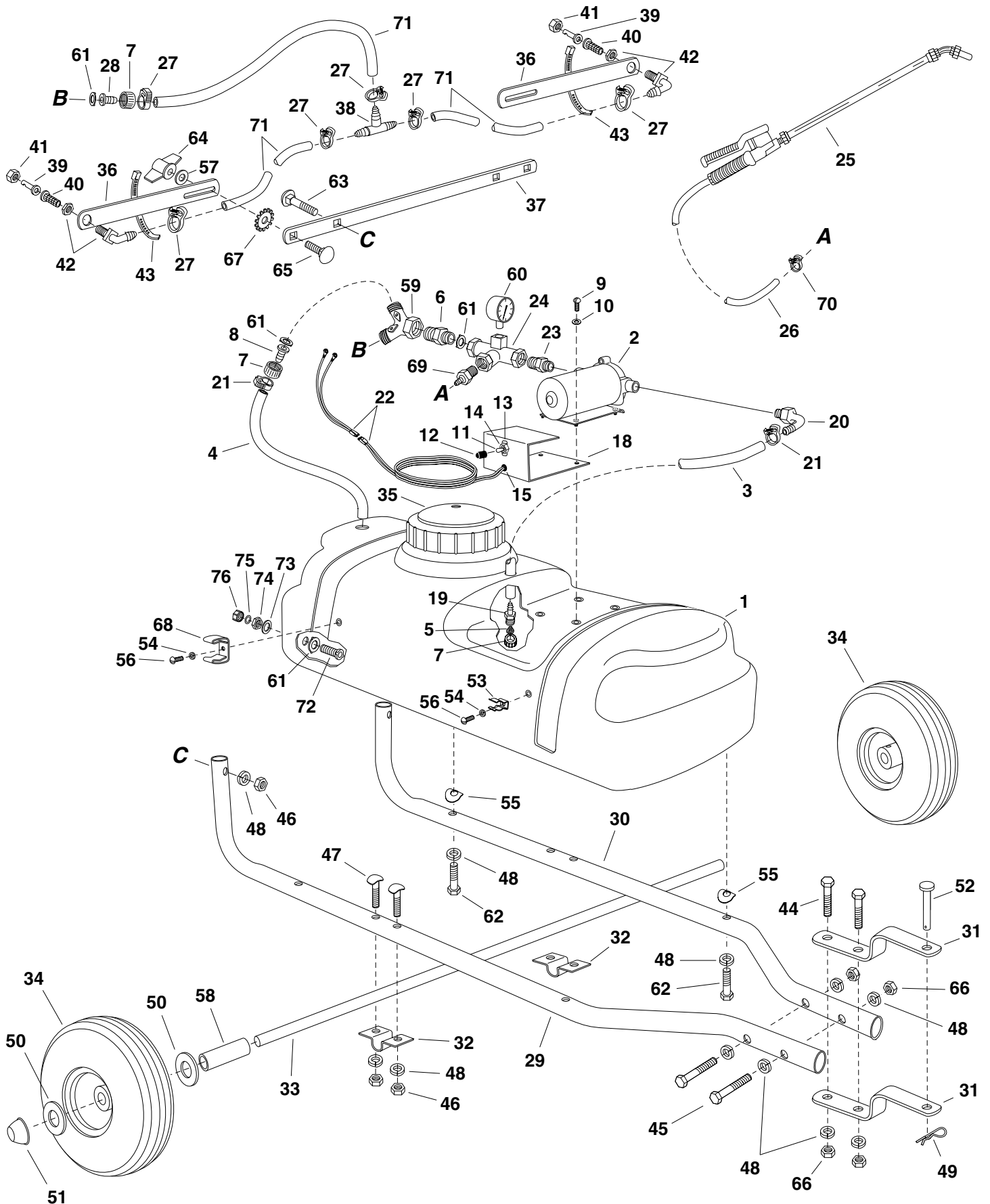

REPAIR PARTS LIST FOR 15 GALLON SPRAYER MODEL 45-0292

REF. NO.	PART NO.	QTY.	DESCRIPTION	REF. NO.	PART NO.	QTY.	DESCRIPTION
1	47752	1	Tank (15 Gal.)	40	45029	2	Strainer, Screen Type
2	45015	1	Pump and Motor	41	45037	2	Nut, Screen Body
3	46278	1	Hose, 1/2" ID (24" Lg.)	42	47396	2	Elbow, Plastic 11/16" Thd.
4	45021	1	Hose, 1/2" ID (20" Lg.)	43	726-0178	2	Nylon Tie
5	45024	1	Strainer, Cap Type 1"	44	43224	2	Bolt, Hex 5/16-18 x 2-1/4"
6	45031	1	Adapter, 1/2" NPT x Hose	45	46782	2	Bolt, Hex 5/16-18 x 3"
7	45032	3	Nut, Swivel 3/4" Garden Hose	46	43083	6	Nut, Hex 5/16-18 Thread
8	45033	1	Hose Barb, 1/2"	47	44947	4	Bolt, Curved Head 5/16-18 x 1-5/8"
9	45069	4	Screw, Ph. Pan Hd. 10-24 x 1" Lg.	48	43086	16	Lock Washer, 5/16"
10	43910	4	Washer, Flat #10 SAE	49	43343	1	Pin, Hair Cotter #4 (1/8")
11	45084	1	Switch, On - Off	50	R19171616	4	Washer, 17/32" x 1"
12	45082	1	Boot, Rubber Switch	51	44663	2	Hub Cap (1/2" Push Nut)
13	45080	1	Plate, On - Off Switch	52	47623	1	Hitch Pin
14	45048	1	Nut, Hex 15/32-32 Thd.	53	45180	1	Hose Clip, Small
15	45087	1	Bushing, Strain Relief	54	736-0722	2	Lock Washer, #10
16	45085	1	Terminal, .25 Male Tab (not shown)	55	44695	4	Washer, Bowed
17	45086	1	Terminal, .25 Female Tab (not shown)	56	45040	2	Screw, Phillips Hd. #10-24 x 1/2"
18	23889	1	Bracket, Switch Mounting	57	43081	2	Washer, 5/16" Std. Wrt.
19	46276	1	Adapter, 3/4" GH x 1/2" Barb	58	46578	2	Spacer
20	46277	1	Elbow, 3/8 NPT x 1/2" Barb	59	45017	1	Hose "Y" W / Valves 3/4"
21	45025	2	Clamp, 1/2" Hose	60	45071	1	Gauge, Pressure 2" 100 PSI
22	45018	1	Connector with Wire	61	45072	4	Gasket, 3/4" Garden Hose
23	45049	1	Nipple, (Nylon) 1/2" x 3/8" Red.	62	43085	4	Bolt, Hex 5/16-18 x 1-1/2"
24	45050	1	Tee, 1/2" x 1/2" x 1/2" (1/4" Port)	63	44215	2	Bolt, Carriage 5/16-18 x 1-3/4"
25	47406	1	Spray Gun	64	712-0421	2	Knob
26	47393	1	Hose, 1/4" ID (12' 6" Lg.)	65	43682	2	Bolt, Carriage 5/16-18 x 1-1/4"
27	45026	6	Clamp, 3/8" Hose	66	43064	4	Nut, Hex Lock 5/16-18 Thd.
28	45034	1	Hose Barb, 3/8"	67	44732	2	Washer, Tooth Lock 5/16"
29	47624	1	Hitch Tube, R.H.	68	47397	1	Hose Clip (Large)
30	47625	1	Hitch Tube, L.H.	69	47390	1	Adapter, 1/2" NPT x 1/4" Barb
31	23014	2	Hitch Bracket	70	47405	1	Clamp, 1/4" Hose
32	24586	2	Clamp, 1/2" Axle	71	47392	3	Hose, 3/8" ID (20" Lg.)
33	24584	1	Axle, 1/2"	72	47399	1	Drain Body
34	47052	2	Wheel	73	47398	1	Washer, Nylon
35	46700	1	Lid	74	47402	1	Nut, Nylon 11/16" Thd.
36	24122	2	Boom Bar	75	47400	1	O-Ring, 5/8" OD
37	24585	1	Bracket, Boom Mount	76	47403	1	Cap, Nylon 11/16" Thd.
38	47394	1	Tee, Plastic 3/8" Hose		47628	1	Owners Manual
39	45028	2	Nozzle, SS Floodjet				

For Agri Fab Discount Parts Call 606-678-9623 or 606-561-4983

REPAIR PARTS
303 West Raymond
Sullivan, IL. 61951
217-728-8388
www.agri-fab.com

www.mymowerparts.com